

Multi-Satellite Observation of Cen A  
RXTE, INTEGRAL, Suzaku, Swift  
Plus  
XMM and Chandra

Richard E. Rothschild

Dan Evans

Katja Pottschmidt

Marcus Kirsch

Alex Markowitz

John Tomsick

Valentina La Porola

Tad Takahashi

Craig Markwardt

Kazuhiro Nakazawa

Jay Cummings

Kokubun Motohide

## Instruments, Livetimes, and Rates

Instrument	Livetime (s)	Rate (0.5-2)	Rate (2-10)	Rate (20-100)
RXTE/PCU2	9,472		$21.54 \pm 0.06$	
RXTE/HEXTE	6,073			$4.62 \pm 0.11$
INTEGRAL/JEMX-1	42,080		$1.27 \pm 0.04$	
INTEGRAL/ISGRI	83,160			$6.59 \pm 0.01$
INTEGRAL/SPI	92,453			$0.0115 \pm 0.0009$
Swift/XRT	10,086	$0.127 \pm 0.004$	$0.662 \pm 0.008$	
Swift/BAT	12,165			$36.3 \pm 1.9$
Suzaku/XIS-FI	212,304	$0.232 \pm 0.001$	$4.51 \pm 0.005$	
Suzaku/XIS-BI	69,018	$0.327 \pm 0.002$	$3.84 \pm 0.007$	
Suzaku/PIN	154,000			$0.471 \pm 0.004$
Suzaku/GSO	61,562			$0.908 \pm 0.013$
Chandra/MEG	98,342	$0.0165 \pm 0.0009$	$0.635 \pm 0.003$	
Chandra/HEG	98,342		$0.774 \pm 0.003$	
XMM/MOS1	18,900	$0.557 \pm 0.009$	$2.38 \pm 0.01$	
XMM/MOS2	18,911	$0.583 \pm 0.009$	$2.38 \pm 0.01$	
XMM/PN	16,664	$1.77 \pm 0.02$	$6.69 \pm 0.02$	

RXTE "Image"

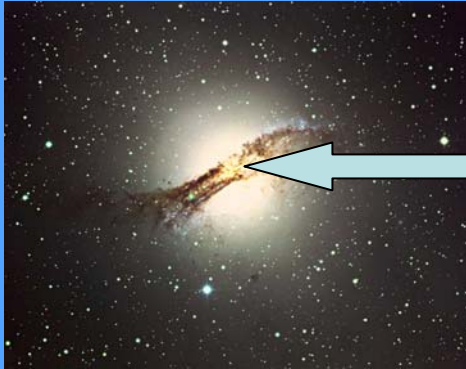

XMM PN Image

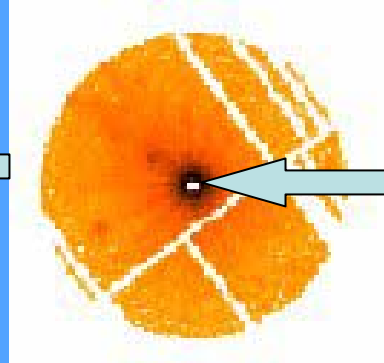

Chandra ACIS Image



Field of view and spatial resolution drastically affect what is included in "the spectrum of the nucleus of Cen A".

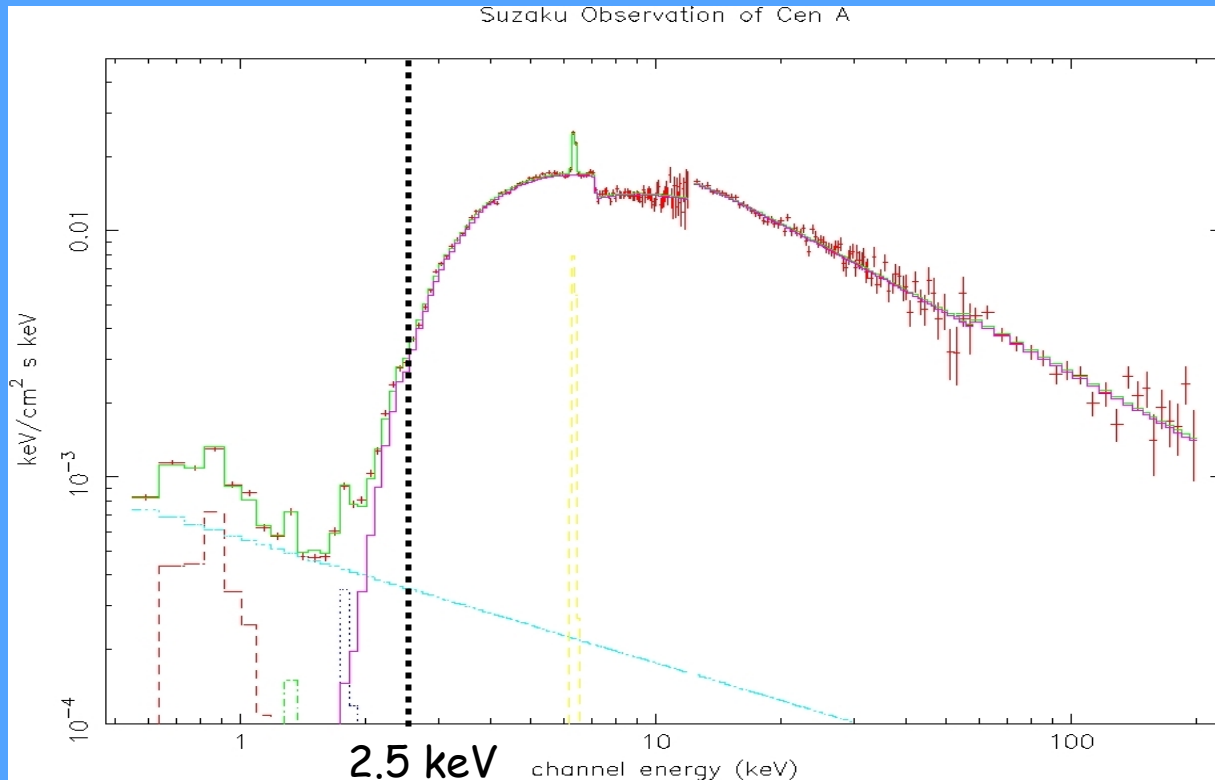

Energy range and energy resolution dramatically affect the modeled spectral components and thereby "the spectrum of Cen A"

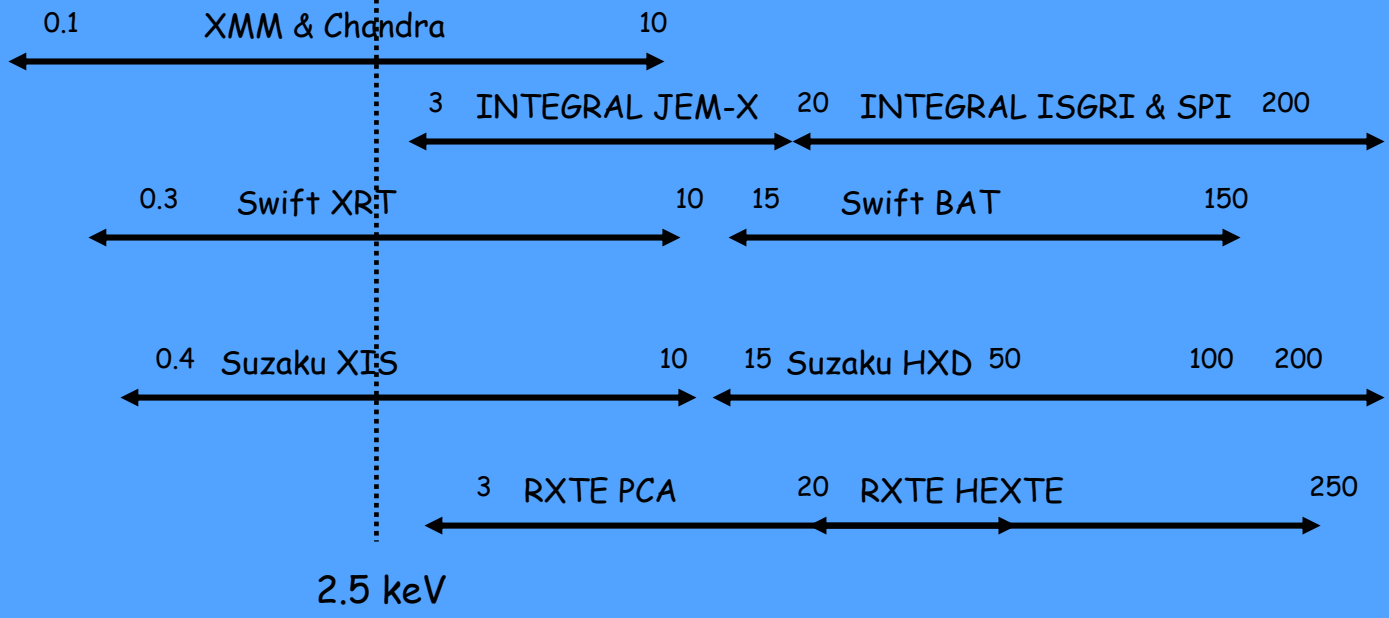
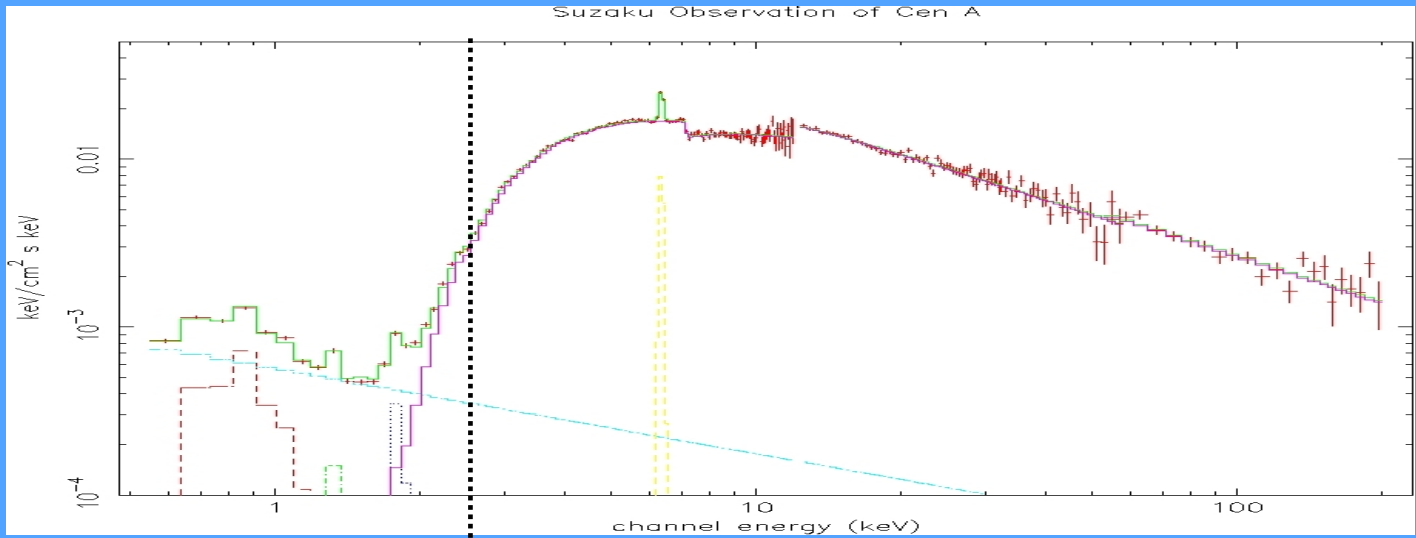

# Cen A Spectrum Above 2.5 keV

## RXTE

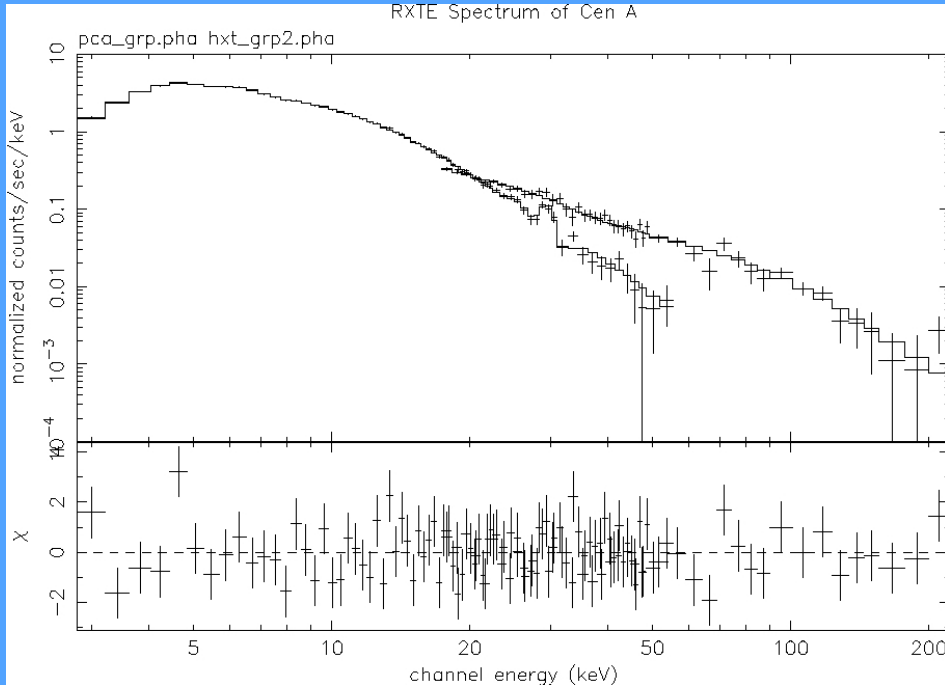

	<u>PCU2</u>	<u>HEXTE</u>	<u>RXTE</u>
$n_H$	$11.2 \pm 0.03$	---	$11.2 \pm 0.4$
$\Gamma$	$1.85 \pm 0.02$	$1.83 \pm 0.06$	$1.85 \pm 0.02$
Norm <sub>2-10</sub>	$389 \pm 9$	---	$390 \pm 8$
Norm <sub>20-100</sub>	---	$500 \pm 21$	---
E(Fe)	$6.32 \pm 0.12$	---	$6.32 \pm 0.12$
F(Fe)	$3.2 \pm 0.8$	---	$3.2 \pm 0.8$
EW	82	---	81
$\chi^2_\nu$	67/61 = 1.09	33/48 = 0.69	100/110 = 0.91

# Cen A Spectrum Above 2.5 keV

## INTEGRAL



	<u>JEMX</u>	<u>ISGRI</u>	<u>SPI</u>	<u>INTEGRAL</u>
$n_H$	$9.3 \pm 3.2$	---	---	$12.3 \pm {}^{0.7}_{1.9}$
$\Gamma$	$1.80 \pm 0.12$	$1.97 \pm 0.05$	$1.76 \pm 0.17$	$1.95 \pm 0.02$
Norm <sub>2-10</sub>	$361 \pm 49$	---	---	---
Norm <sub>20-100</sub>	---	$612 \pm 12$	$817 \pm 72$	$545 \pm 29$
E(Fe)	6.32	---	---	6.32
F(Fe)	$\leq 2.0$	---	---	$\leq 1.9$
EW	---	---	---	---
$\chi^2_v$	$78/63 = 1.24$	$21/17 = 1.23$	$18/18 = 1.00$	$123/99 = 1.25$

# Cen A Above 2.5 keV

## Swift

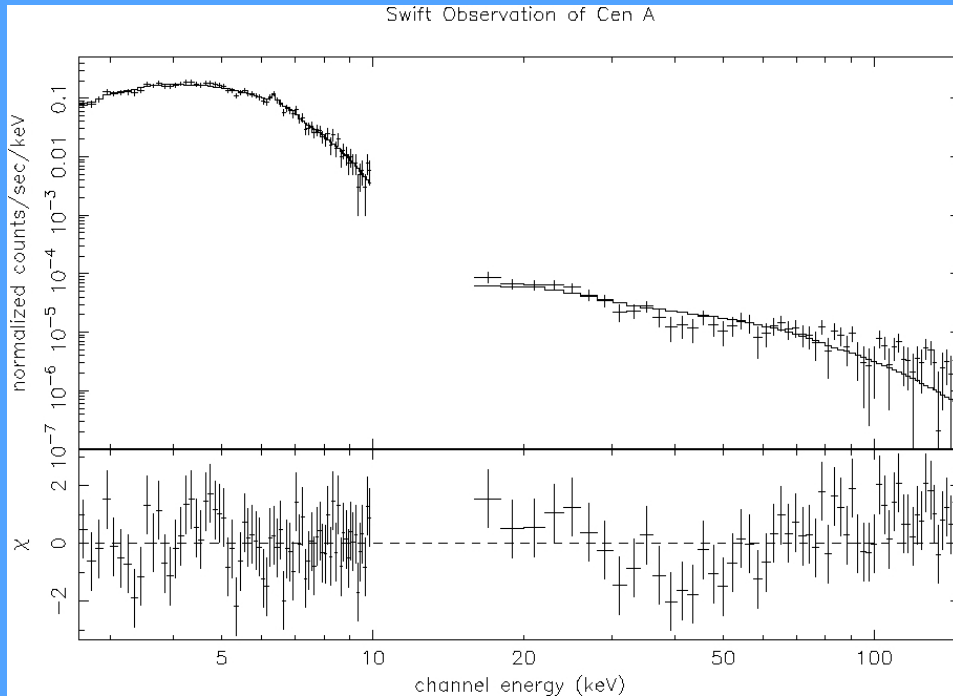

	<u>XRT</u>	<u>BAT</u>	<u>Swift</u>
$n_H$	$9.8 \pm 1.1$	---	$9.1 \pm 0.9$
$\Gamma$	$1.83 \pm 0.17$	$1.57 \pm 0.18$	$1.71 \pm 0.13$
$\text{Norm}_{2-10}$	$384 \pm 29$	---	$369 \pm 20$
$\text{Norm}_{20-100}$	---	$688 \pm 54$	---
$E(\text{Fe})$	$6.36 \pm 0.04$	---	$6.35 \pm 0.05$
$F(\text{Fe})$	$3.2 \pm 1.5$	---	$3.0 \pm 1.5$
$\text{EW}$	81	---	76
$\chi^2_\nu$	$59/68 = 0.87$	$68/456 = 1.22$	$131/125 = 1.05$

# Cen A Above 2.5 keV

## Suzaku

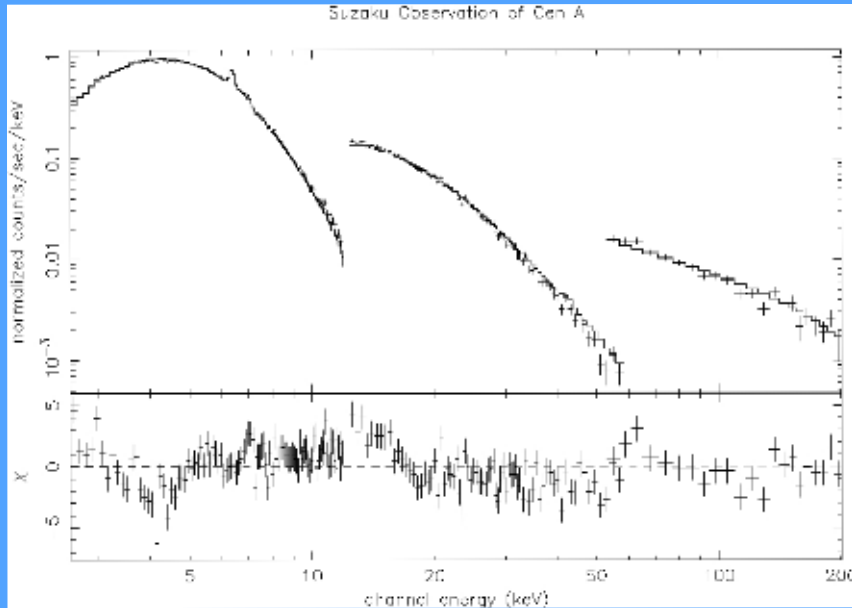

	<u>XIS-BI</u>	<u>PIN</u>	<u>GSO</u>	<u>Suzaku</u>
$n_H$	$9.8 \pm 0.15$	---	---	$10.6 \pm 0.13$
$\Gamma$	$1.57 \pm 0.02$	$1.84 \pm 0.03$	$1.97 \pm 0.11$	$1.72 \pm 0.02$
$\text{Norm}_{2-10}$	$289 \pm 3$	---	---	---
$\text{Norm}_{20-100}$	---	$630 \pm 15$	$641 \pm 48$	$304 \pm 2$
$E(\text{Fe})$	$6.37 \pm 0.01$	---	---	$6.38 \pm 0.01$
$F(\text{Fe})$	$2.6 \pm 0.2$	---	---	$2.7 \pm 0.2$
EW	80	---	---	---
$\chi^2_\nu$	$168/98 = 1.71$	$90/75 = 1.20$	$26/20 = 1.31$	$562/195 = 2.88$
	<u>XIS-FI</u>			
$n_H$	$10.0 \pm 0.1$			
$\Gamma$	$1.68 \pm 0.02$			
$\text{Norm}_{2-10}$	$312 \pm 2$			
$E(\text{Fe})$	$6.37 \pm 0.004$			
$F(\text{Fe})$	$2.7 \pm 0.1$			
EW	81			
$\chi^2_\nu$	$256/98 = 2.61$			

## Cen A Above 2.5 keV

### XIS BI & FI

Due to the higher energy resolution and sensitivity of the XIS telescopes, weaker features are significant.

Iron edge at  $7.17 \pm 0.04$  keV with  $\tau \sim 5 \times 10^{-2}$

Another edge at  $3.40 \pm 0.03$  keV with  $\tau \sim 5 \times 10^{-2}$

Emission line at  $3.66 \pm 0.03$  keV with Flux of  $5 \times 10^{-5} \text{ cm}^{-2} \text{ s}^{-1}$  or EW = 6 eV

These features and others need to be taken into account when calibrating high sensitivity instruments with good energy resolution, but they do not significantly affect continuum measurements.

Including them changed the fitted power law index by <1%.

## Results from Continuum fitting above 2.5 keV

RXTE/PCU2 index of  $1.85 \pm 0.02$  defines the continuum

-- Low index outliers:

BAT at  $1.57 \pm 0.18$

XIS-BI at  $1.57 \pm 0.02$

XIS-FI at  $1.68 \pm 0.02$

-- High index outlier:

ISGRI at  $1.97 \pm 0.05$

Suzaku/XIS defines iron line energy ( $6.37 \pm 0.05$  keV)

and line flux ( $2.7 \pm 0.1 \text{ cm}^{-2}\text{s}^{-1}$ )

All 4 missions agree with this within errors.

But what about low energy absorption?

Low energy telescopes and PCU2 disagree on  $n_H$  but this may be a function of the power law index in which they also do not agree.

Could it be the limited energy range of the telescopes? No!

Fitting PCU2 in the 2.5--12 keV range yields

$$n_H = 11.6 \pm 0.5 \times 10^{22} \text{ cm}^{-2}$$

$$\Gamma = 1.88 \pm 0.03$$

$$E(\text{Fe}) = 6.33 \pm 0.13 \text{ keV}$$

$$\text{Flux}(\text{Fe}) = 2.9 \pm 1.0 \times 10^{-4} \text{ cm}^{-2}\text{s}^{-1}$$

Something is amiss in the telescope calibrations.

# Do Chandra and XMM also fit to a flatter power law index --- YES!!

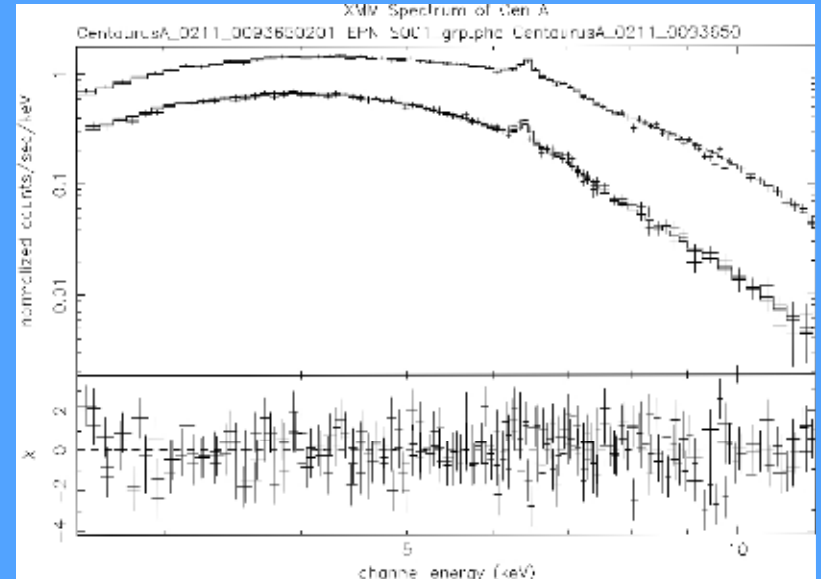
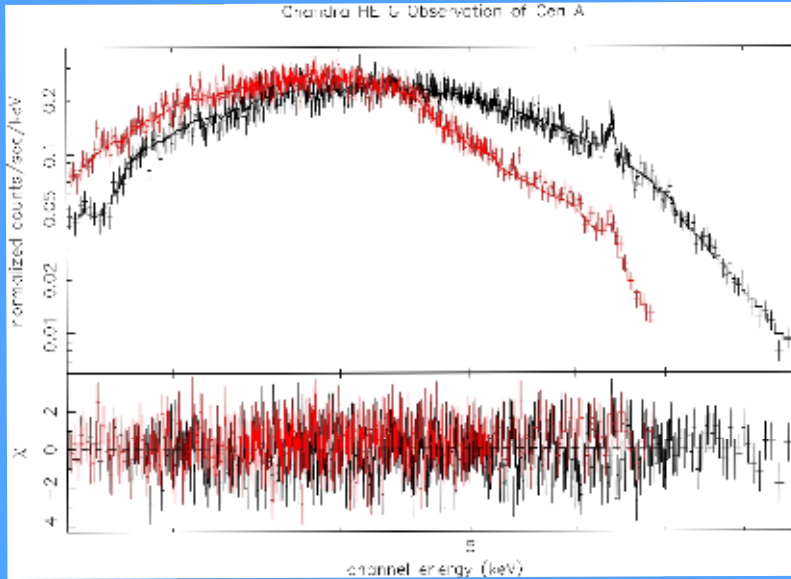

Chandra HETG:

$$n_H = 9.9 \pm 0.3 \times 10^{22} \text{ cm}^{-2}$$

$$\Gamma = 1.57 \pm 0.06$$

$$E(\text{Fe}) = 6.37 \pm 0.01 \text{ keV}$$

$$F(\text{Fe}) = 3.1 \pm 0.5 \times 10^{-4} \text{ cm}^{-2} \text{ s}^{-1}$$

XMM

MOS1

MOS2

PN

$$n_H = 0.2$$

$$8.4 \pm 0.4$$

$$8.6 \pm 0.4$$

$$8.6 \pm$$

$$\Gamma = 0.04$$

$$1.56 \pm 0.08$$

$$1.65 \pm 0.08$$

$$1.69 \pm$$

$$E(\text{Fe}) = 0.02$$

$$6.42 \pm 0.02$$

$$6.38 \pm 0.02$$

$$6.44 \pm$$

$$F(\text{Fe}) =$$

$$3.4 \pm 0.7$$

$$3.3 \pm 0.7$$

$$2.5 \pm 0.3$$

# Cen A Below 2 keV

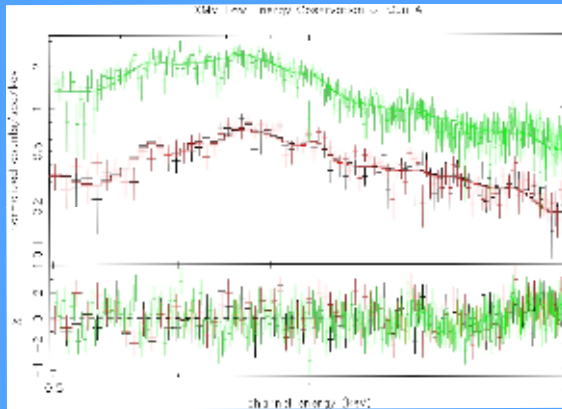

XMM

Apec kT =  $0.64 \pm 0.02$   
 Apec Norm =  $6.8 \pm 0.4 \times 10^{-4}$   
 Power Law  $\Gamma = 1.01 \pm 0.04$   
 Flux(1 keV) =  $2.01 \pm 0.03 \times 10^{-3}$   
 Line Energy =  $0.651 \pm 0.012$   
 Line Flux =  $1.5 \pm 0.5 \times 10^{-4}$   
 EW = 33.5

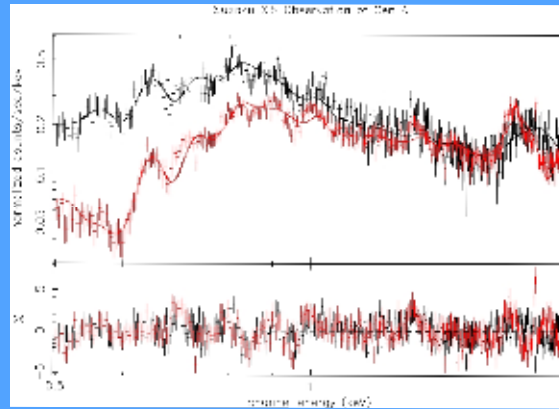

Suzaku

$0.62 \pm 0.01$   
 $2.1 \pm 0.8 \times 10^{-4}$   
 $0.89 \pm 0.06$   
 $0.56 \pm 0.01 \times 10^{-3}$   
 $0.641 \pm 0.004$   
 $0.38 \pm 0.07 \times 10^{-4}$   
 27.0

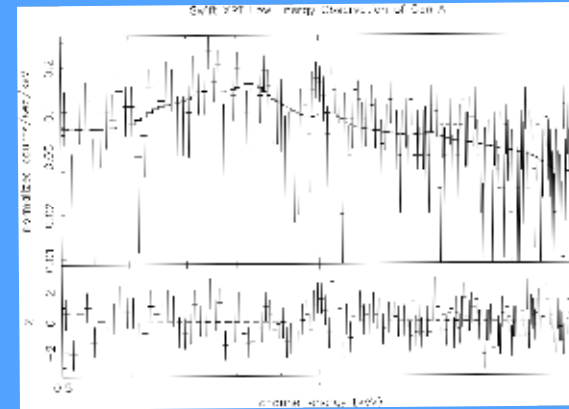

Swift

$0.42 \pm 0.07$   
 $12.6 \pm 4.0 \times 10^{-4}$   
 $0.84 \pm 0.44$   
 $2.1 \pm 0.5 \times 10^{-3}$   
 ---  
 ---  
 ---

## Cen A Below 2 keV

Results below 2 keV appear to be very calibration and systematics dependent.

An Apec plus power law model can be the basis for beginning to understand the Cen A flux.

Variable abundances and better energy calibration may help with the additional lines required for each instrument.

Systematics associated with front or back illumination, variable contamination, instrumental lines, and sizes of extraction regions may very well dominate our detailed knowledge of emission processes below 2 keV.

## Summary of the Inter-calibration above 2.5 keV

### Power Law Index:

RXTE/PCU2:  $1.85 \pm 0.02$   
RXTE/HEXTE:  $1.83 \pm 0.06$   
INTEGRAL/JEMX:  $1.80 \pm 0.12$   
**INTEGRAL/ISGRI:  $1.97 \pm 0.05$**   
INTEGRAL/SPI:  $1.76 \pm 0.17$   
**Swift/BAT:  $1.57 \pm 0.18$**   
Suzaku/PIN:  $1.84 \pm 0.03$   
Suzaku/GSO:  $1.97 \pm 0.11$

Swift/XRT:  $1.83 \pm 0.17$   
Suzaku/XIS-BI:  $1.57 \pm 0.02$   
Suzaku/XIS-FI:  $1.68 \pm 0.02$   
XMM/MOS1:  $1.56 \pm 0.08$   
XMM/MOS2:  $1.65 \pm 0.08$   
XMM/PN:  $1.69 \pm 0.04$   
Chandra/HETG:  $1.57 \pm 0.06$

RXTE/PCU2 (2.5--10):  $1.88 \pm 0.03$

RXTE:  $1.85 \pm 0.02$   
INTEGRAL:  $1.95 \pm 0.02$   
Swift:  $1.71 \pm 0.13$   
Suzaku:  $1.72 \pm 0.02$

Power law index is probably 1.85 and steady.

## Summary of Iron Line Measurements

RXTE/PCU2:	$6.32 \pm 0.12$ keV	$3.2 \pm 0.03 \times 10^{-4}$ cm <sup>-2</sup> s <sup>-1</sup>
Swift/XRT:	$6.36 \pm 0.04$	$3.2 \pm 0.15$
Suzaku/XIS-BI:	$6.37 \pm 0.01$	$2.6 \pm 0.02$
Suzaku/XIS-FI:	$6.37 \pm 0.004$	$2.7 \pm 0.01$
XMM/MOS1:	$6.42 \pm 0.02$	$3.4 \pm 0.07$
XMM/MOS2:	$6.38 \pm 0.02$	$3.3 \pm 0.07$
XMM/PN:	$6.44 \pm 0.02$	$2.5 \pm 0.03$
Chandra/HETG:	$6.37 \pm 0.01$	$3.1 \pm 0.05$

Line energy is most probably near 6.37 keV with a flux near  $3.3 \times 10^{-4}$  cm<sup>-2</sup> s<sup>-1</sup>

## Summary of Using Cen A as a Calibration Source

1. Spectrum above 2.5 keV and up to at least 200 keV is an absorbed power law with an iron emission line and edge.
2. The line of sight absorption is variable between 1 and  $1.5 \times 10^{23} \text{ cm}^{-2}$ , so that must be fit for each observation.
3. The power law photon index appears to be stable at  $1.85 \pm 0.01$  over the last decade, as seen by RXTE and BeppoSAX.
4. While the 2-10 and 20-100 keV fluxes vary by as much as 50%, the power law index remains unchanged.
5. The iron line energy of 6.37 may be stable, but we do not have enough high resolution measurements to know for sure.
6. The iron line flux appears to be stable to 20% over the last decade.

**BOTTOM LINE:** Use the power law index for continuum calibrations with broad band instruments, but figure out why 2--10 keV measurements with focusing telescopes consistently derive indices  $\Delta\Gamma \sim 0.2$  flatter.