

HEXTE Phoswich Detector

HEXTE Phoswich Detector Assembly

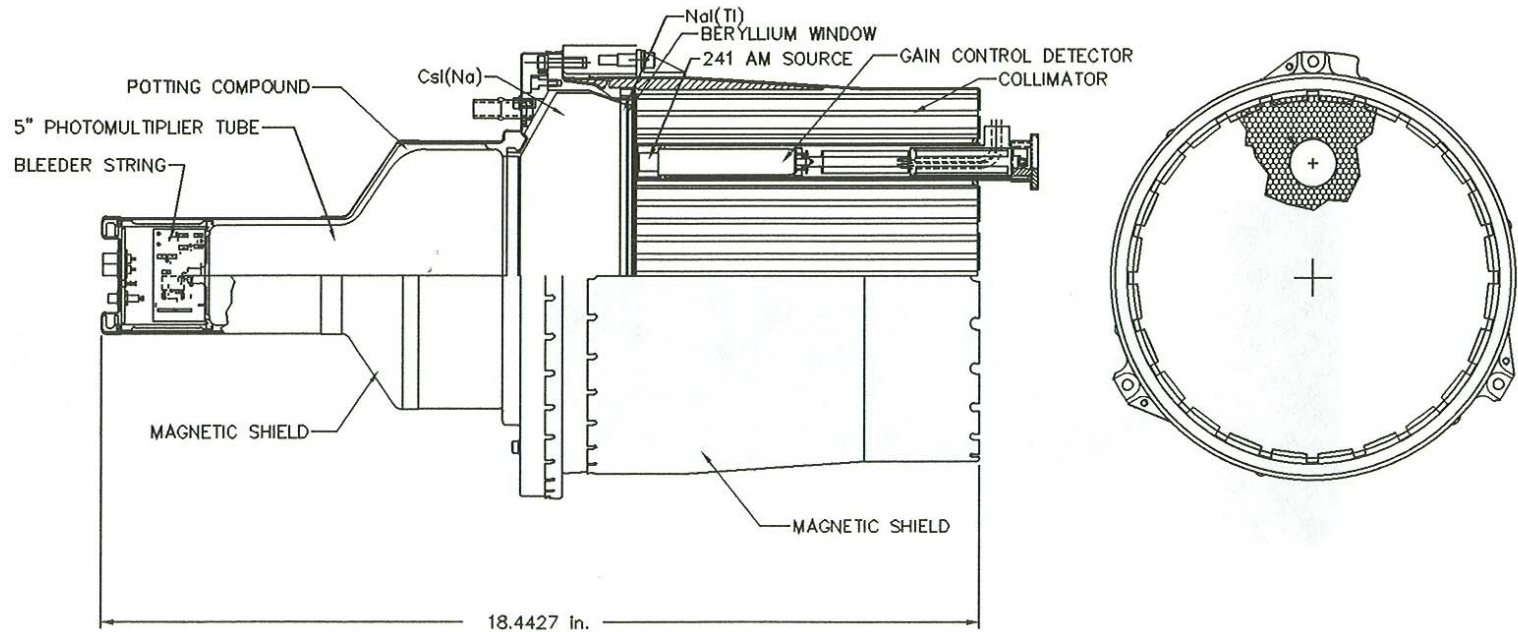

HEXTE Features

Aperture
Modulator

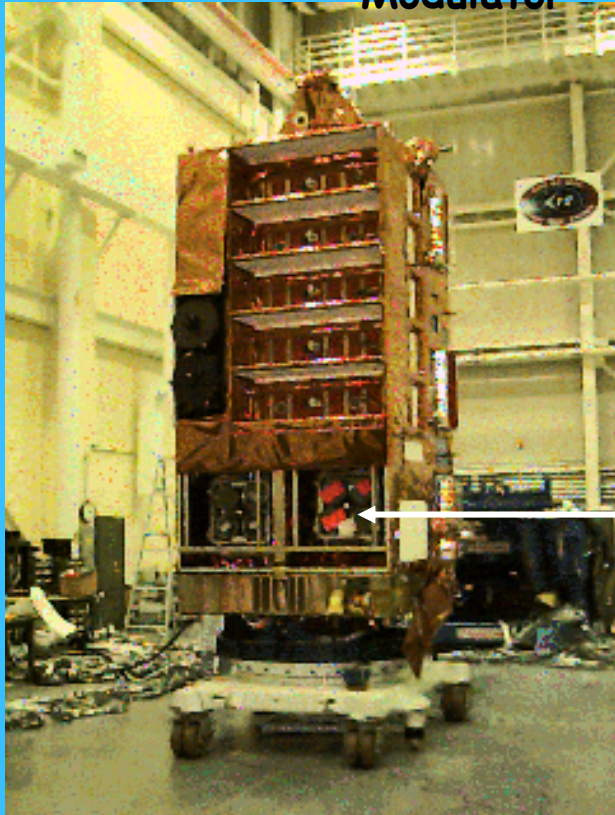

AGC Detector

"Mu Metal" Housing

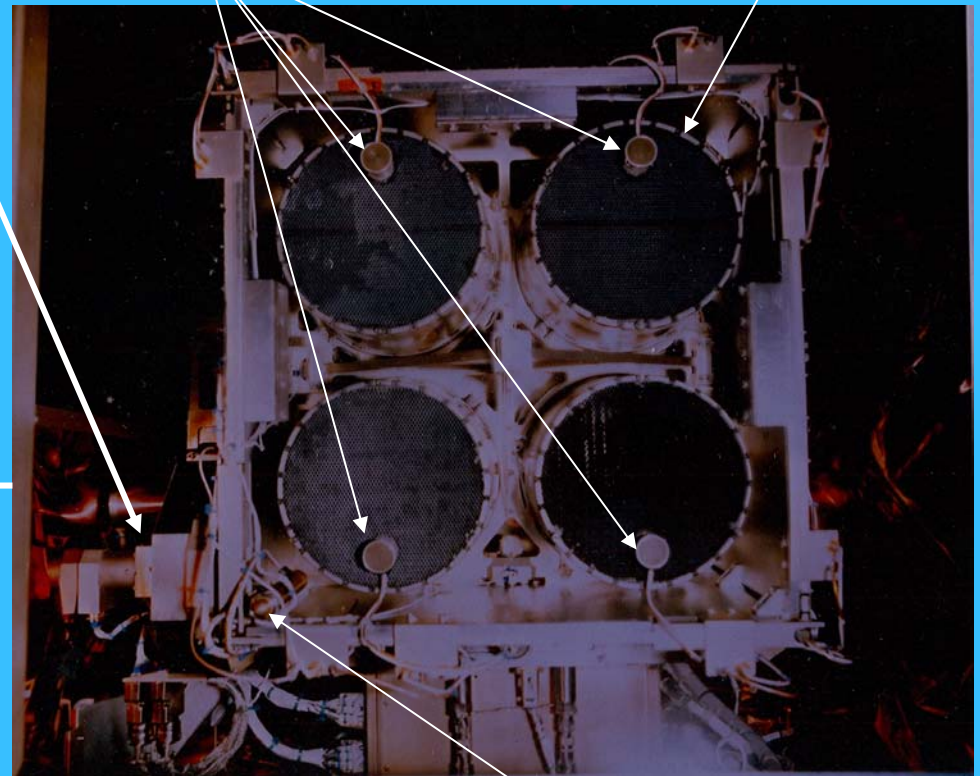

Particle Monitor

RXTE/HEXTE Design and Calibration

- Calibration begins with instrument design.
- Instrument design begins with previous experience,
"Oh, if I only could have ..."
- and advances with a clear statement of top level requirements.
"HEXTE will measure point-like X-ray sources within the intensity range 0.01 to 100 times background in the 15--250 keV range with 10 μ s time resolution and better than 18% energy resolution"
- Control of systematics allows for easier calibrations.

HEXTE Features to Address Systematics

<u>Problem</u>	<u>Solution</u>
Source Confusion	Narrow Field of View
Magnetic Field Variations (>10 s)	Automatic Gain Control
Phototube Aging	Automatic Gain Control
Detector Interface Degradation	Automatic Gain Control
Summing Data from Different Detectors	Automatic Gain Control
Magnetic Field Variations (<1 minute)	Aperture Modulation
Cosmic Ray Induced Background Variations	Aperture Modulation
Knowledge of Observation Background	Aperture Modulation
Source Confusion in Background Region	Aperture Modulation
Magnetic Field Variations (<10 s)	Magnetic Shielding
PMT Aging due to SAA	Particle Monitor
Charged Particle Background	Particle Shields

HEXTE Aperture Modulation Pattern

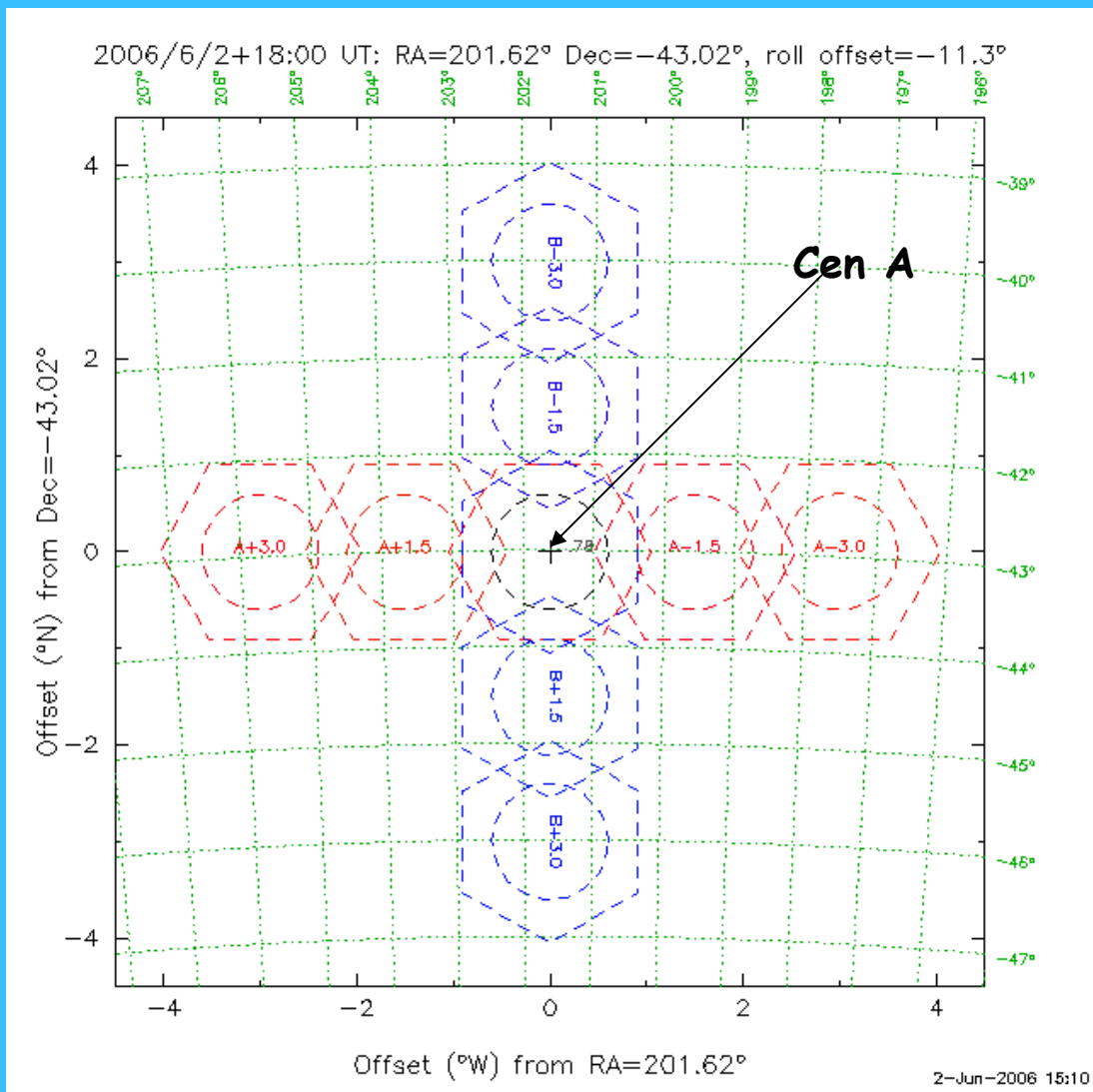

HEXTE Calibration Spectrum

The tagged ^{241}Am spectrum can be used beyond gain control.

- 1) Measurement of individual detector Energy Resolution
- 2) Measurement of HEXTE Energy Resolution (7 or 8 summed detectors)
- 3) Dead time measurement for intervals of >10 minutes

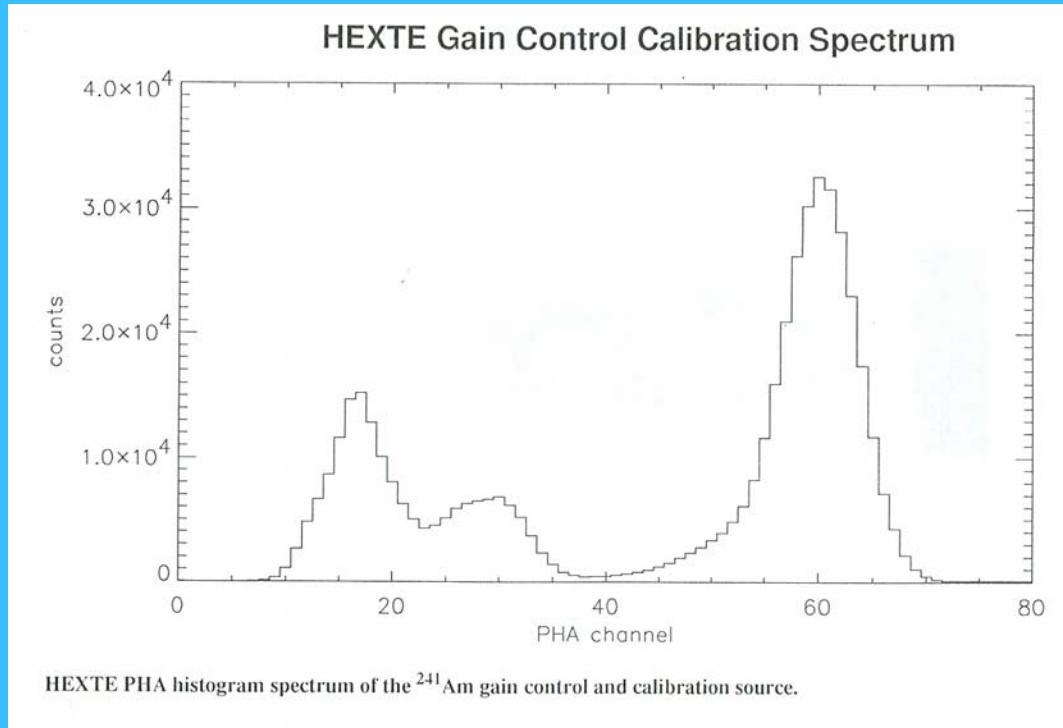

HEXTE Ground Calibration -- Instrument Response

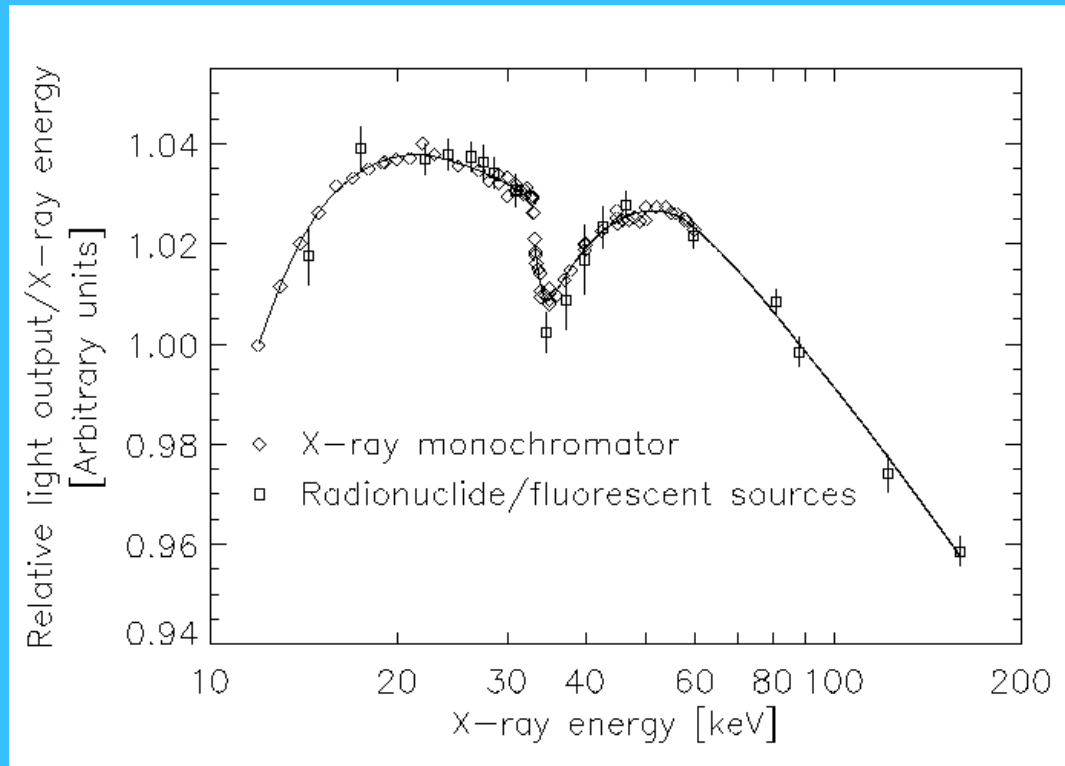

Synchrotron Source at Brookhaven National Lab plus laboratory fluorescent targets and sources were used to measure the HEXTE NaI response to X-rays. The response shape was spline fit for input to the response generator. K-escape fraction versus energy was also measured at Brookhaven.

HEXTE Calibration -- Energy Resolution

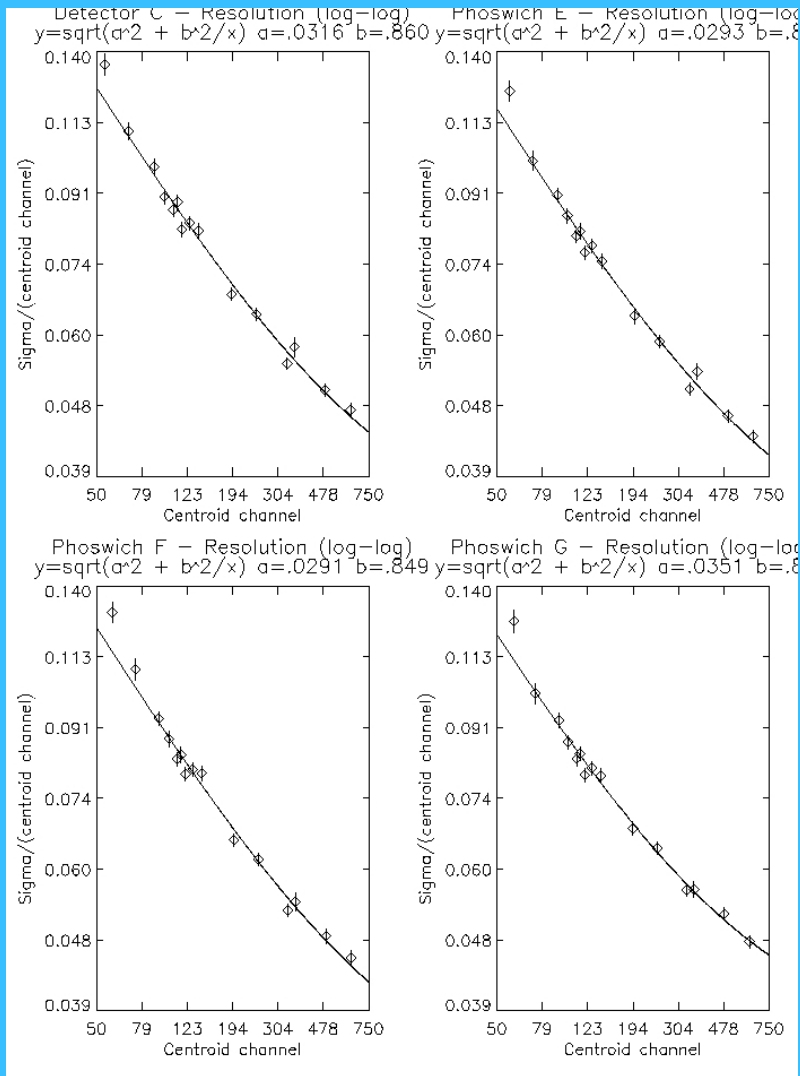

All of the detectors could not be taken to the synchrotron beam for detailed calibration.

Use the beam results to get general shape and then use lab sources to match each detector to the general shape.

Laboratory fluorescent targets and sources gave the energy resolution vs energy, that was fit to a two parameter quadratic.

HEXTE Collimator Response -- Ground Measurement

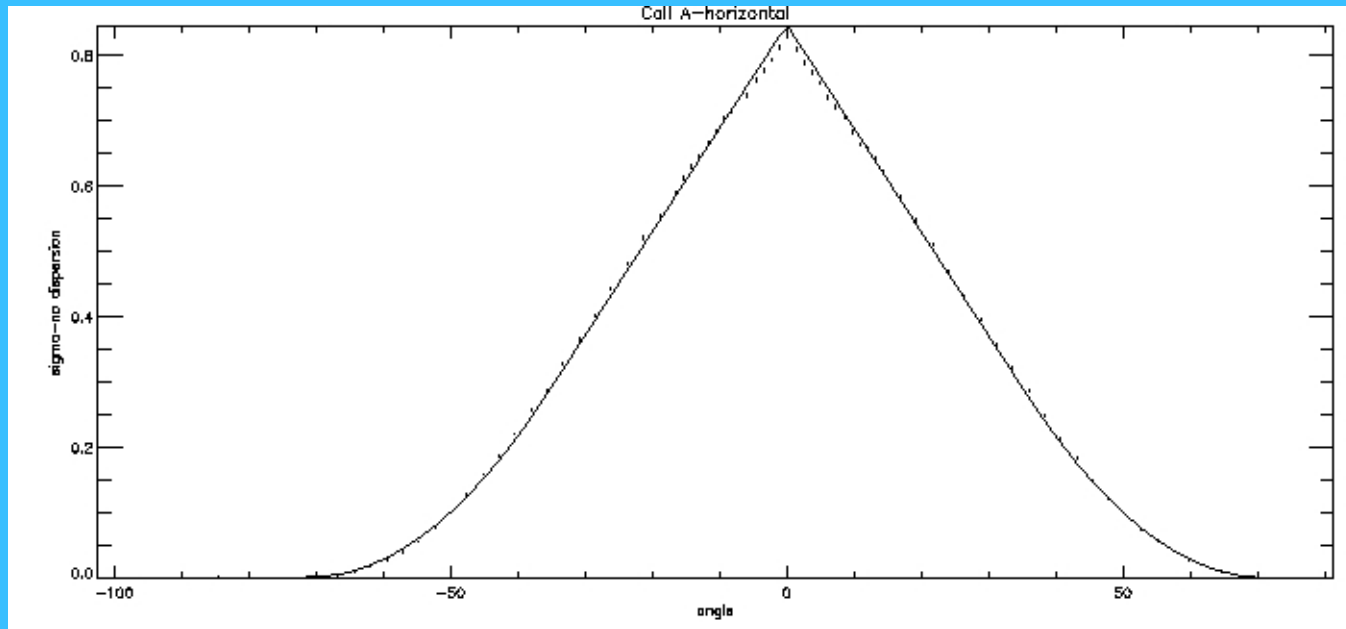

Measurements made in two orthogonal directions for the hexagonally shaped collimator elements -- point to point and flat to flat. With the ^{241}Am source "only" 110 feet away, one must correct for dispersion in the point source "beam".

HEXTE Calibration Efforts Once in Orbit

- Scan across Crab Nebula at different offsets to measure true aperture response to parallel beam of X-rays. This yields open area per detector and mounting offsets
- Measure phoswich efficiency for rejecting charged particle and multiple site events (I.e., Compton scattering or K-escape into CsI)
- Measure Crab spectrum and “fudge” instrument response to get “universal value”.
- Measure Crab pulsar timing to determine offsets, if any, to universal time.

HEXTE Crab Observations in AO1 and AO5

$$\Gamma = 2.078 \pm 0.003$$

$$F_{20-100 \text{ keV}} = 1.792 \pm 0.003$$

$$\text{Bkd Correction} = 0.07 \pm 0.11\%$$

$$\text{Livetime (src)} = 23,465 \text{ s}$$

$$\text{Livetime (bkg)} = 17,644 \text{ s}$$

$$\Gamma = 2.088 \pm 0.003$$

$$F_{20-100 \text{ keV}} = 1.813 \pm 0.003$$

$$\text{Bkg Correction} = 0.58 \pm 0.10\%$$

$$\text{Livetime (src)} = 19,183 \text{ s}$$

$$\text{Livetime (bkg)} = 16,920 \text{ s}$$

